



PEW Electrical Distributors

Display



IRIS 3.5"

High resolution landing and car position indicator



MAIN FEATURES

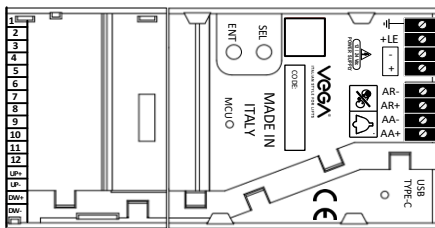

- Easy configuration via onboard menu or PC with SIRIO Software
- **Onboard buzzer** for gong (landing)
- Updating by USB-C only
- Customisable backgrounds, running & next direction arrows, floors and icons
- **EN 81-70 compliant**
- ECO Energy saving system mode (stand-by switch off)
- Emergency light functionality
- Communication interface: Vega serial, RS485, CAN, parallel and magnetic sensors
- Protection: enclosed plastic case
- Orientation: horizontal and vertical
- Compact design: 144.4mm x 61mm x 18mm
- **Direct connection to Standalone Reed Switches & Magnet System - no encoder needed**

Technical Data:

Dimensions: 3.5"
 Visible area: 74 x 49mm.
 Resolution: 480(RGB) x 320
 Pixel (mm): 0.198x0.198mm2.
 Colours: 65,000
 Energy consumption: 160mA(max)
 Power supply: 12/24V dc
 Temperature range: -5/+50°C
 Encumbrance: 144.4x61x18mm

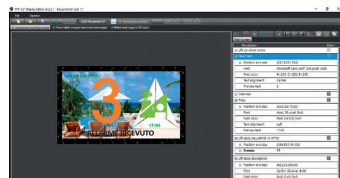

SIRIO

- Intuitive dedicated programming software
- Easily customize your TFT layout
- Inbuilt fonts and arrow design option
- Change display orientation
- Export to microSD Card for display update

ORDER CODES

TFT350RS485 : Iris TFT 3.5" display for VEGA RS485 connection.
 SNV201/1WSPK: 1Watt Speaker (for speech)
 SNV201/5WSPK: 5Watt Speaker (for speech)
 SNV201ENC-VG: VEGA Encoder with Speech for Binary, Gray, 1PF
 SNV201/FIX: DIN Rail Fixing for PCB

PEW Electrical Distributors Ltd

Unit 1 The iO Centre
 59-71 River Road
 Barking, Essex IG11 0DR

0208 507 1001

sales@pewelectrical.com
 www.pewelectrical.com

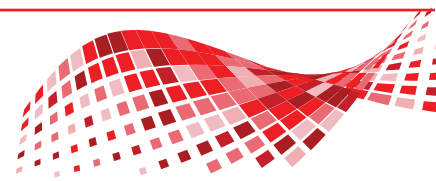

DIMENSIONS

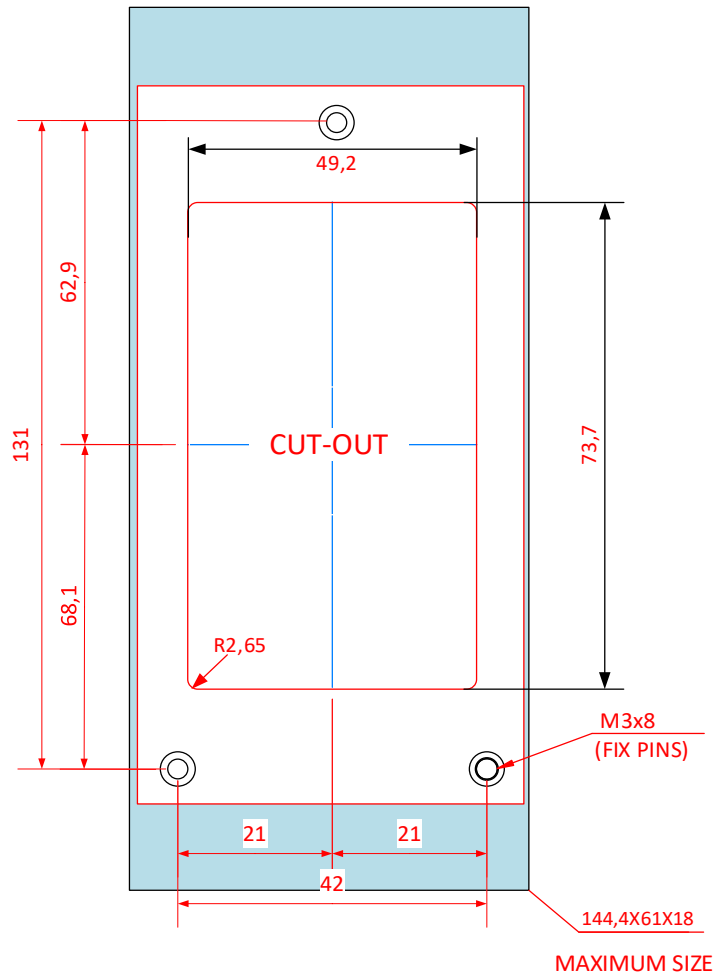

INTERFACES

SNV201:ENC

- RS485 serial encoder board (4-wire) to car & landing
- Binary or Gray input
- Maximum 32 stop
- Default or configurable service message input
- Configure set-up onboard via button
- Inbuilt Speech with separate speaker (1W or 5W)
- Update speech using .wav files to MicroSD Car

